





 **Switch<sup>2</sup>**

**REVERSIBLE AIR-BAG HARNESS WITH SPLIT LEGS**

Whilst Gin Gliders has made every effort at the time of publication to provide accurate information, product specifications are subject to change without notice and may vary from those shown.

# CONTENTS

Switch<sup>2</sup>

Thank you .....	1
Warning .....	2
About Gin Gliders .....	3
Specifications .....	4
Features .....	5
Before You Fly .....	6
Flying with the Switch <sup>2</sup> .....	20
Maintenance and Repairs .....	23
Final Words .....	26
Harness Diagram .....	27

# THANK YOU

**For choosing Gin Gliders. We are confident you'll enjoy many rewarding experiences in the air with your new GIN harness.**

This manual contains important safety, performance and maintenance information. Read it before your first flight, keep it for reference, and please pass it on to the new owner if you ever re-sell your rescue.

Any updates to this manual, or relevant safety information, will be published on our website: [www.gingliders.com](http://www.gingliders.com). You can also register for e-mail updates via our website.

Happy flying and safe landings,  
GIN Team



## **!** WARNING

Like any extreme sport, paragliding involves unpredictable risks which may lead to injury or death. By choosing to fly, you assume the sole responsibility for those risks. You can minimize the risks by having the appropriate attitude, training and experience and by properly understanding, using and maintaining your equipment. Always seek to expand your knowledge and to develop self-reliance. If there is anything you do not understand, consult with your local dealer as a first point of contact, with the GIN importer in your country or with Gin Gliders directly.

Because it is impossible to anticipate every situation or condition that can occur while paragliding, this manual makes no representation about the safe use of the paragliding equipment under all conditions. Neither Gin Gliders nor the seller of GIN equipment can guarantee, or be held responsible for, the safety of yourself or anyone else.

Many countries have specific regulations or laws regarding paragliding activity. It's your responsibility to know and observe the regulations of the region where you fly.

**INTENDED USE:** *Lightweight air sports equipment with a maximum mass of less than 120kg, operated in the paragliding division.*

# SPECIFICATIONS

Size	One size
Harness weight (kg)*	2.4
Pilot height (cm)	155-190
Rucksack volume (l)*	80

## CERTIFICATION

The Switch 2 has EN certification, max load 120daN  
Certification Number: PH IP 198.2017

## DELIVERY PACKAGE (APPROX. WEIGHTS)

- 1 Harness convertible to rucksack
- 1 Main rescue handle and inner container (100g)
- 1 Main rescue bridle (75g)
- 2 Carabiner (130g)
- 1 Speedbar (2 step) (100g)

## SIZING

One size fits pilots from 155cm to 190cm height.



# FEATURES...

As usual safety is a priority for Gin Gliders. The Switch 2 has achieved a very good drop test result of 1000g, with less airbag volume than the Switch 1 this is a big step forward for our design team. The under-seat reserve with shoulder attachment points offers the best safety during a rescue deployment. The rescue container has been redesigned to aid a more efficient opening and closing sequence especially in higher G situations. The T-lock get up safety system helps decrease the risk of pilots forgetting to connect the leg straps.



Choosing only the best quality materials, buckles, zippers and state of the art fabrics. You will notice the difference.



The new rucksack layout has greatly improved the comfort and load distribution while carrying the harness. In flight the Switch 2 is a comfortable sit up harness designed for leisure pilots. The Switch 2 comes without seat plate. The Switch 2 is one of our most versatile harness, suitable for pilots from the training hill to hike and fly even for the first cross country flights. The new geometry offers improved stability in the turn while also dampening out turbulence to give the pilot a more comfortable feeling. This new geometry allows only one size fitting a wide range of pilots.



# BEFORE YOU FLY

Make sure your dealer has checked the harness for completeness and basic settings. Your harness must be assembled by a suitably qualified paragliding professional, for example, your instructor.

Gin Gliders recommends that assembly be carried out in the following order. If you are in any doubt whatsoever about this procedure, please seek professional advice from your instructor, GIN dealer or importer.

## INSTALLING THE SPEED SYSTEM

Assemble the speed system from top to bottom. Pass the chord along the inside of the harness and route it through the Speed pulley (1). From the pulley, route the chord through the metal ring at the bottom edge of the seat (2). From the metal ring, to the plastic opening (3). Connect the chord to the speedbar using a secure knot (4).

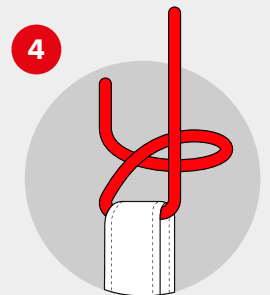
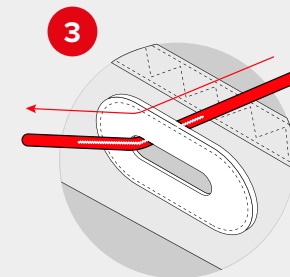
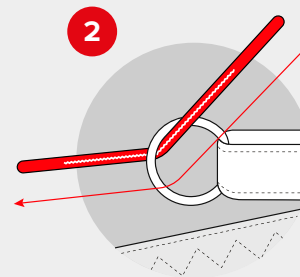
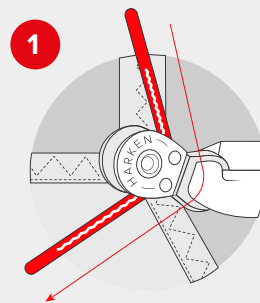
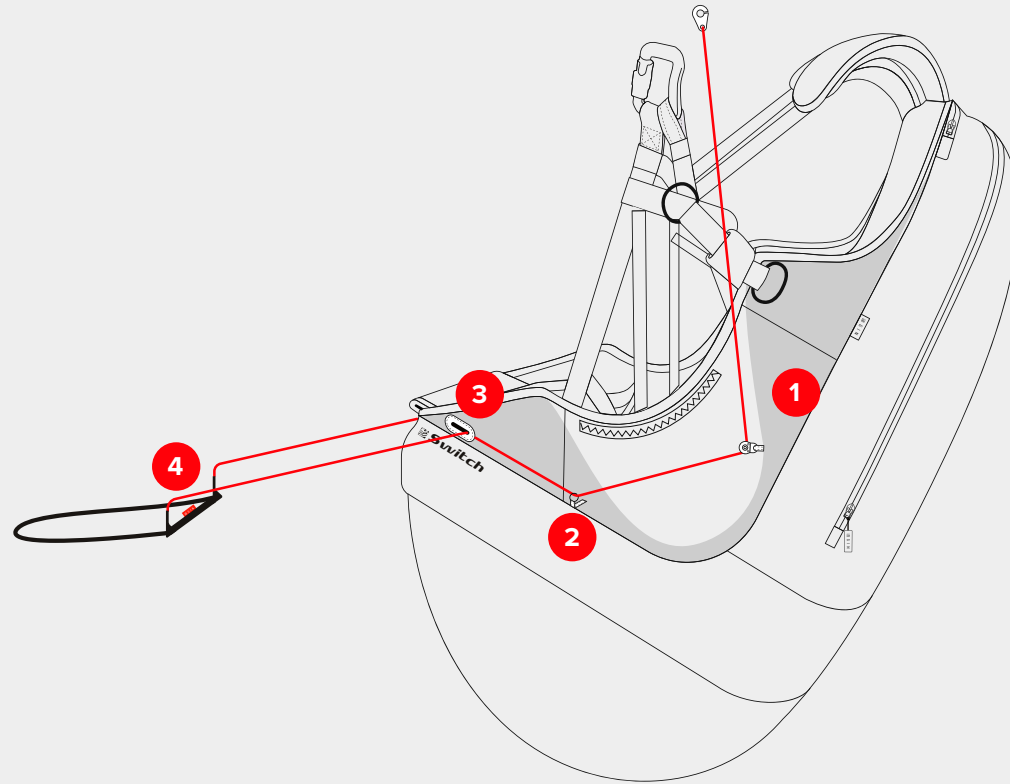

**! CAUTION:** Make sure that the speed system is not too short. The front risers of your paraglider must not be pulled down in normal (unaccelerated) flight.

## CONNECTING THE RISER CARABINER

The riser carabiner connection has 2 harness straps that must be attached, however the 2 webbings are connected together for convenience. Follow the image to the RIGHT to properly connect the riser carabiner to the harness webbing. The RIGHT side of harness has BLUE webbing connection, the LEFT side of the harness has a RED webbing connection to match GIN Glider risers for a safe and easy connection.

QUICK-OUT Carabiners are not compatible with the Switch 2.

**! WARNING:** *Forgetting to close the leg straps may place the pilot at risk of falling out of the harness*



**BLUE** webbing indicates the **RIGHT** side of the harness.

## AIRBAG BAG PROTECTION

The advantage of the airbag back protection is the increased safety rating compared to other technologies once fully inflated. Also the packing volume is reduced and the harness is lighter compared to a conventional foam protector.

The airbag inlet is located between the legs of the pilot just below the seat plate. On takeoff the harness will be mostly inflated before the pilot is airborne thanks to the designed pre-inflation which is aided by Titanium wire a thin foam layer. After takeoff the harness is normally fully inflated in a matter of seconds.

In the event of an incident the inflated back protection will help to dissipate the force of the impact. However, the back protection cannot completely eliminate the risk of injury to the pilot.

**⚠ WARNING:** *The back protection does not eliminate the chance of injury as a result of a crash.*

**⚠ WARNING:** *If the harness is subjected to temperatures exceeding 70 degrees Celsius the integrity of the back protection may be compromised.*

**⚠ WARNING:** *After any strong impact the back protection should be professionally inspected for external or internal damage. Any damage can decrease the effectiveness of the back protection.*



**NOTICE:** *The back protection is EN / LTF certified.*

## RESCUE INSTALLATION AND COMPATIBILITY CHECK

Gin Gliders recommend that rescue installation is performed properly by a competent person. The rescue parachute is a pilot's last resort and failure to pack or connect the reserve parachute in the correct way may cause death or severe injury. The pilot is responsible for ensuring proper installation.

This harness is compatible with the Yeti UL, G-Lite, Yeti and Yeti Cross rescue parachutes. Other manufacturers' rescues may also be used but we cannot guarantee their function. The pilot is responsible for checking compatibility.

Every first installation of a rescue system into the harness (that means every new combination of harness and rescue system) must be checked by a qualified paragliding professional for compatibility. To verify the installation, you must perform a test deployment by sitting in a simulator.

Rescue parachutes should be repacked at least every 150 days; so installing your rescue in a new harness may also provide a good opportunity for a repack. After every repack of the rescue parachute you should also do a compatibility check.

## RESCUE COMPATIBILITY

**MAKE SURE THAT THE RESCUE PARACHUTE CAN BE RELEASED FROM THE RESCUE CONTAINER —** it must be done by you, the pilot, sitting in the harness hanging from a simulator.



**! WARNING:** *If you are in any doubt about any aspect of rescue installation, seek professional advice!*

**i IMPORTANT:** *You must perform a test deployment from a simulator to verify the correct installation.*

## THE RESCUE DEPLOYMENT BAG AND THE HARNESS DEPLOYMENT HANDLE

The rescue container for this harness comes with its own deployment handle. This handle and its strap must be connected to the deployment bag of the parachute. In particular, check the length of the strap connecting the rescue deployment handle to the rescue inner container. It should be long enough that the reserve can be extracted without the danger of the pins not being pulled before the strap tightens on the reserve, but not so long that there is excessive slack that extends the movement required for deployment.

The deployment bag of other manufacturers' rescue systems (i.e. non-GIN rescue systems) may have different loop positions which may cause a deployment failure. Be sure to contact your parachute dealer or a qualified professional to check the connection, position and secure deployment, and refer to the rescue manual for details.

The rescue handle and inner container supplied with the Switch 2 should already be connected.

## INNER BAG



**i IMPORTANT:** *The deployment bag of other manufacturers' rescue systems may have different loop positions which may cause a deployment failure.*

*\* Rescue and handle may differ*

## RESCUE INNER BAG PACKING

Your rescue should be repacked into the supplied inner containers as follows.



1 Place the folded rescue into the inner bag.



2 Fold 60cm of line under the rescue. Secure the suspension line using the central elastic band.



3 Fold the para-cord into symmetrical bundles the approximate width of the bag.



4 Close the bottom flap in the order shown. (Fig. 4 to Fig. 8)



7 Use elastic bands to hold the loops and neatly stack the bundles at the bottom of the bag.



8 There should be around 40cm of suspension line remaining to connect with the harness.

## CONNECTING THE RESCUE BRIDLE

To connect a rescue to your harness we recommend using a GIN Rescue Carabiner. If you choose to use different type of connector, it should be rated at least 9 times the maximum weight. For example, our recommended 7mm Stainless Steel screw-gate maillon (square) connector has a minimum breaking load of 28kN (2855 Kgf). It is the pilot's responsibility to check the compatibility of the rescue system and ensure that it is installed properly.

Be sure to inspect your connector during normal maintenance and safety checks. Replace it whenever there are any signs of wear and check your rescue system with a professional after any deployment. We recommend that you cover the connection using the Maillon rapid cover to prevent excess friction. Rubber-bands should also be used to secure the attachment and prevent excess friction.

**Recommended by GIN: 7mm stainless steel screw-gate maillon**

**7mm square maillon**  
**Breaking load: 28kN**

**! WARNING:** *When connecting the rescue bridle be sure to secure the connection using tape, rubber bands or heat shrink wrap. If the bridles are not secure they may burn or cut from excess friction.*

**i IMPORTANT:** *Be sure to connect both rescue bridles to the rescue.*

**Maillon connection** *(Recommended by Gin Gliders)*



## RESCUE INSTALLATION GUIDE

It is very important to properly install the rescue parachute. If the parachute is not folded correctly or the lines are not placed properly then a serious if not fatal accident could result. If you have any doubts speak with your instructor or GIN dealer.

## RESCUE INSTALLATION GUIDE

Begin by first connecting the Y bridle and the rescue handle to the rescue parachute . Install the rescue into the harness with the handle connection FACING UP and the extra para line neatly folded on the bottom of the container. Be sure that the inner bag is installed so the rescue handle loop is facing the opening of the rescue container.

Using parachord install your rescue into the harness in the order shown and on the next page:

**! WARNING:** *When installing the reserve make sure the reserve handle is up and the reserve lines are facing down.*

**! CAUTION:** *Check the zipper of the rescue bridle cover after any hard landing or dragging at takeoff, as it may have opened.*

### Rescue compartment volumes:

	One size
Main Rescue	7.5 L



# OPTION 1



After connecting the rescue to rescue bridle, insert rescue with handle facing UP



Move zipper to the shown position



Pass the paracord through the closing loops



Use paracord to pull the closure loops through the secondary loops. Start to do up the zippers for 10cm



Pass the handle wire through the closing loop in front



Pass the handle wire through the second closing loop in the back



Secure the handle wire in the housing left and right as shown and slowly remove paracords



Secure rescue handle in the pocket and close the flap as shown

## RESCUE BRIDLE TUNNEL

There are 2 attachment points for reserve parachutes on the Switch 2 are located near the upper shoulder connection point, between the back pocket and the harness.

The Switch 2 uses zipper bridle tunnels for the rescue bridles. The zipper bridle tunnel offers superior opening and reduced drag in flight. When using a zipper bridle tunnel it is very important to run the zipper closure ALL the way from END-to-END to prevent damage to the harness or opening failure during rescue deployment.

## RESCUE BRIDLE

The main rescue bridle and rescue bridle tunnel is located just behind the harness shoulder connection point. The rescue bridles are connected using a “figure 8” knot and can be replaced if damaged.

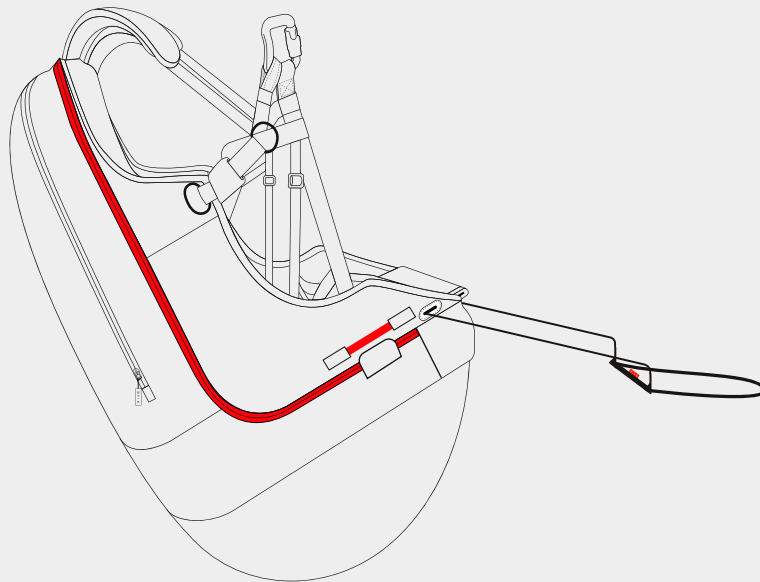

**i IMPORTANT:** The rescue bridle tunnel zipper must be closed from end-to-end.

## STORAGE

### Back pocket (1)

The back pocket is designed to store personal stuff and light accessories during flight.

### Side pockets (2)

Located on both sides of the harness, just under the carabiners, are two pockets that can be used to store small items such as a snack or small digital camera during your flight. The right side pocket has a zipper for closing and securing important items while the left side is closed by elastic fabric for easy access in flight.

### Shoulder Straps (3)

For better aerodynamics the shoulder straps are covered with neoprene and there is no pocket there, you may use the side pockets for SPOT or other small items.

### Optional Radio Pocket (4)

The radio pocket attaches to either shoulder strap and comes equipped with a hook knife.

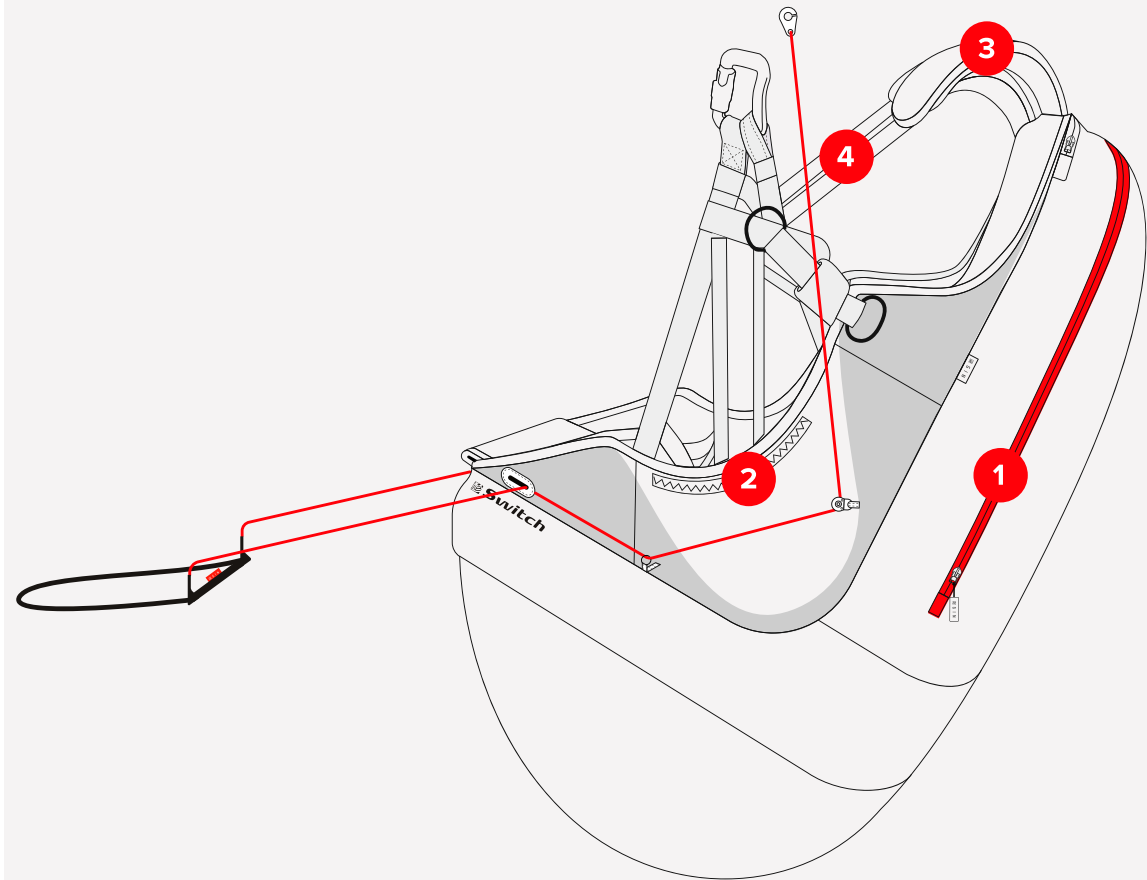

## Adjustments

After choosing a harness that is close to your body size, adjust your harness to suit your physique and flying style. It is important to adjust it correctly to ensure you can easily slide into the sitting position after take off. A poorly adjusted harness can adversely affect the flying characteristics of your paraglider.

Perform adjustments before your first flight by hanging in a simulator and fine-tune the settings if necessary during your first few flights.

## Shoulder straps

The optimum setting for the shoulder straps depends on the height of the pilot. Step into the harness and stand upright with the breast strap closed, symmetrically adjust the shoulder straps until they are a snug fit, but not tight.

Tighten: pull down on the black and green loop

Loosen: pull up on the BLACK loop on the top of the shoulder strap.

## Leg straps

The correct adjustment of the leg straps allows the pilot to easily reach the sitting position after take-off without using his hands. Use the buckles to adjust the leg straps so that they fit comfortably without being tight; make sure you do it symmetrically. If you need to lengthen the leg straps, first check that the shoulder straps are not too tight.

## Chest Strap

The Chest strap can be adjusted while in flight to match the flying condition and pilots flying style.

Wide: the pilot will feel more feedback from the glider and will have more body weight control.

Narrow: the pilot will feel less turbulence and is a better position for long glides on speedbar.



**NOTE:** Make sure that the rescue system has been installed before making adjustments.

## Lateral Straps (1)

The lateral straps adjust the angle between the thighs and the back. Lengthening the straps increases the angle and vice-versa. The easiest way to adjust them correctly is during a flight in calm air. Remember that flying in the supine position (i.e. leaning back), reduces the stability of the harness and increases the risk of riser twists after a deflation.

To tighten, pull forward on the black/green loop. To loosen, pull backwards on the red/white loop.

## Seat Straps (2)

The seat straps change the depth of the seat. Adjust to find a comfortable position. In the sitting position, lengthen the straps to their maximum at first and then use the buckles to shorten the straps to find a comfortable position with good back support. Lengthening the straps also helps you to slide easily into the harness at take off, while shortening the straps helps you to be in the standing position for landing. The webbing is not adjustable in-flight, use your first few flights to fine tune the setting as you like.

## Speed Bar (3)

Hanging in the simulator, adjust the length of the speed bar chord so that the bar hangs at least 15cm below the front of the harness. Making the chord too short could result in the speed system being constantly or unintentionally engaged during flight. It is safer to start with the speed bar a little long and shorten it following your first flights. Test the speed bar in flight only after you are comfortable with your new harness, and always do so in calm conditions with enough clearance above the ground.

**NOTE:** *Even though we use the best buckles currently available, there is a slight chance that straps might move, especially when the harness gets old. A tape or a few stitches will prevent the straps from sliding.*

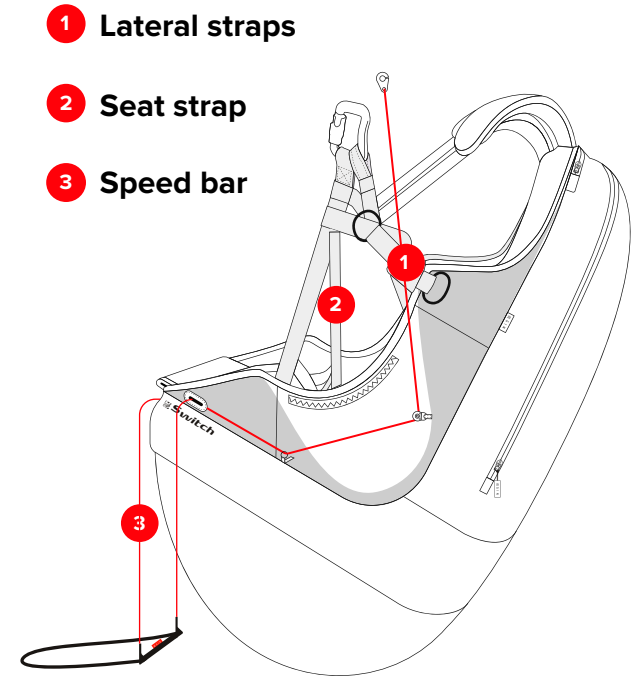

## Rucksack

Place all the harness webbings and straps close to the back plate when you turn the harness into the rucksack. Ensure the lateral straps are folded inwards to maintain the shape and ergonomics of the rucksack.

Place the packed wing into the rucksack and close the zipper and compress the bag as required with the compression straps.



# FLYING WITH THE SWITCH 2

## General warnings and advice

Before every flight, check the following:

- ⦿ Are you in good physical and mental condition?
- ⦿ Are you familiar and compliant with all applicable laws and regulations in your area?
- ⦿ Are you within the certified weight range of your paraglider?
- ⦿ Do you have the necessary valid insurance cover (e.g. liability, medical, life)?
- ⦿ Are you briefed thoroughly about the site, airspace and expected weather conditions of the day?
- ⦿ Is your equipment and choice of site suitable for your level of experience?
- ⦿ Do you have a suitable helmet, gloves, boots, eye-wear and adequate clothing?
- ⦿ Are you carrying some form of identification, so that people know who you are in case of an accident? Take along a radio and mobile phone if possible.
- ⦿ Do you fully understand how to safely use your new equipment? If not, have your instructor or dealer explain anything you are not sure about.

When you go for your first flight on your new harness, be sure to pick a day and site that does not present you with any unfamiliar challenges. During your first flight, familiarize yourself with the in-flight characteristics of your new harness.

## Pre-flight checks

As part of your normal pre-flight check routine, check:

- ⦿ Is there any damage to the harness or carabiners that could affect its airworthiness?
- ⦿ Is the rescue parachute container closed correctly with the pins in the right position?
- ⦿ Is the deployment handle correctly inserted or attached?
- ⦿ Are all buckles, belts, zips securely fastened? Buckles should click into place as you close them, and ⦿ gentle pull on the fastened buckle verifies this. Secure any zips after fastening the buckles. Take extra care in snowy or sandy environments.
- ⦿ Is the paraglider connected correctly to the harness with both carabiners secured by their locking mechanisms?
- ⦿ Is the speed bar attached correctly to the glider?
- ⦿ Are all pockets closed properly and any loose items tied down safely?
- ⦿ Is the air chamber intake open and clear?
- ⦿ Have you closed your leg and chest straps? Double check before you take off!



**i IMPORTANT:** Use a complete and consistent system of pre-flight checks and repeat the same sequence every flight.

**i IMPORTANT:** The maximum clip in weight of the Switch 2 is 120kg, we do not recommend you fly with more than this weight.

## Rescue Deployment

In the event of an emergency, you must quickly evaluate your height and the seriousness of the incident. A seconds hesitation in deploying the reserve could prove fatal if there is insufficient height. On the other hand, deploying the rescue when the glider is recoverable may result in needless injury.

If you decide to deploy the rescue:

- 1) Look for the rescue handle and grasp it firmly with one hand
- 2) Pull forwards and upwards on the handle to release the deployment bag from the rescue container.
- 3) Look for a clear area, and in a continuous motion, throw (and RELEASE!) The rescue away from yourself and the glider, preferably into the air stream or against the direction of spin. After deployment, avoid entanglement and pendulum motions by promptly pulling in the glider as symmetrically as possible with the B, C, D or brake lines.
- 4) On landing take an upright body position and be prepared to do a PLF (Parachute Landing Fall) to minimize the risk of injury.

## Landing with the Switch 2

Before landing, slide your legs forward in the harness so that you adopt the standing position. NEVER land in the seated position—it is very dangerous even if you have back protection. Standing up before landing is an active safety precaution.



**i IMPORTANT:** *In normal flight, periodically feel the position of the rescue handle so that the action of reaching for the rescue handle is instinctive in an emergency.*

**! WARNING:** *During any incident in flight, always monitor your altitude. If you have any doubt that you have sufficient height for recovery, deploy your reserve without hesitation. “If in doubt, get it out!”.*

**NOTE:** *After any rescue deployment, it is essential to have your harness thoroughly inspected by a qualified professional to be sure there is no damage to the rescue connection points, rescue bridle or any other parts.*

## Miscellaneous



### Towing

The Switch 2 can be used for towed launches. The Gin Towing Bridle can be hooked directly to the main carabiners. For further details, refer to the documentation provided with your tow release, or ask a qualified towing instructor at your flying site.



### Tandem Flying

The Switch 2 is not designed for tandem flying. See [www.gingliders.com](http://www.gingliders.com) for details of our harnesses specifically designed for tandem flying.



### Flying over water

Water landings should be avoided at all costs, as the back protection increases the risk of the pilot floating in a head-down position. For safety training over water, we recommend wearing a proper flotation vest with a head support holding the wearer's head above the surface even when unconscious.

# MAINTENANCE AND REPAIRS

The materials used in this harness have been carefully selected for maximum durability. Nevertheless, keep your harness clean and airworthy to ensure the longest possible period of safe operation.

## Care and maintenance

Don't drag your harness over rough or rocky ground. Avoid unnecessary exposure to UV rays, heat and humidity. Keep the folded harness in your rucksack when not in use.

Store all your equipment in a cool, dry place, and never put it away while damp or wet. Regularly clean off dirt with a plastic bristled brush and/or a damp cloth. If the harness gets exceptionally dirty, wash it with water. Make sure you first remove the entire sub-components for example, rescue parachute etc. Allow the harness to dry naturally in a well ventilated area away from direct sunlight. If your rescue parachute ever gets wet (e.g. in a water landing) you must separate it from the harness, dry it and repack it before putting it back in its separate deployment bag.

After a hard landing you must check your harness and back protector for damage, pay close attention to the rescue container and verify all of the attachments are secure.

## Inspection checklist

The pilot should perform the following inspection on every repack of the rescue and should be checked by a professional after 24 months or 200 hours of flying. (Whichever comes's first). Additional inspections should be performed after any crash, bad landing or take off, or if there are any signs of damage or undue wear. Always seek professional advice whenever in doubt.

**! IMPORTANT:** *Any repairs should only be carried out by the manufacturer or by an approved agent. This will ensure that the correct materials and repair techniques are used.*

**! IMPORTANT:** *No harness should ever be flown if there is any kind of damage to the webbing.*

### The following checks should be carried out:

- ⦿ Check all webbing, straps and buckles for wear and damage (ex. open seams, tearing or cutting), especially the areas that are not easily seen, such as the inside of the carabiner hook-in points.
- ⦿ All sewing must be intact and any anomalies attended to immediately to avoid exacerbation of the problem.
- ⦿ Special attention should be paid to the rescue installation, particularly the elastic and Velcro parts.
- ⦿ The main carabiners must be replaced at least every 5 years or after 500 hours, whatever comes first. Impacts may create undetectable cracks that could result in structural failure under continuous load.
- ⦿ A careful visual inspection of the protector should be made, airbags should be filled with air and checked for leaks, mousbag should be inspected for tears and foam recovery.

### Repairs

The manufacturer or an official GIN dealer should carry out any repair that involves critical parts of the harness. This will ensure that the correct materials and repair techniques are used.

### Storage

Stored at a temperature between 10° and 25° C and in relative humidity between 50 and 75%. Make sure that the harness is not stored in a place where animals such as mice or cats could use it as a place to sleep.

Do not store the harness near any chemicals (including water). Petrol, for example, causes the material to disintegrate and can cause considerable damage to your harness. When your equipment is in the car boot, keep it as far away as possible from any spare petrol cans or oil containers.

The harness should not be exposed to extreme heat. High temperatures accelerate the process of hydrolysis, particularly when combined with moisture, which damages fibers and coating. Do not store your harness near radiators or other heat sources.



## **GIN quality and service**

We take pride in the quality of our products and are committed to putting right any problems affecting the safety or function of your equipment and which are attributable to manufacturing faults. Your GIN dealer is your first point of contact if you have any problems with your equipment.

If you are unable to contact your dealer or GIN importer, contact Gin Gliders directly via our website.

## **GIN lifetime guarantee**

Gin Gliders are proud to guarantee the quality, craftsmanship and performance of all our products. Equipment with defects in materials or manufacturing will be repaired or replaced at the discretion of Gin Gliders for the practical lifetime of the product. Equipment damaged through wear and tear, misuse or neglect may be repaired at a nominal charge.

If you have any problems with your equipment, please contact your GIN dealer in the first instance, or Gin Gliders directly via our website.

## **Care of the environment**

We are privileged to fly in areas of outstanding natural beauty. Respect and preserve nature by minimizing your impact on the environment. When visiting an area, contact the local club for details of environmentally sensitive areas and local restrictions.

Gin Gliders gives consideration to the entire life cycle of its harnesses, the last stage of which is recycling in an environmentally-friendly manner. The synthetic materials used in a harness must be disposed of properly. If you are not able to arrange appropriate disposal, Gin Gliders will be happy to recycle the harness for you. Send the harness with a short note to this effect to Gin Gliders Inc.

## **Product registration**

Register this product to receive safety updates, and improved guarantee and repair service.

[www.gingliders.com/register](http://www.gingliders.com/register)



# FINAL WORDS...

Most of us today live in a dependent society where we are regulated and protected. There are few opportunities for individuals to develop the self-responsibility that is the foundation of safety in extreme sports such as paragliding.

Most accidents are caused by getting into situations that are too demanding for your level of experience. This happens if you lack fundamental understanding, are incapable of assessing the risk or simply do not pay sufficient attention to your surroundings or your own state of mind.

To stay safe, the best you can do is to increase your understanding, skill and experience at a rate you can manage safely. There is no substitute for self-responsibility and good judgment.

In the end, paragliding offers a unique opportunity to learn to take control of your own destiny. Memento mori, carpe diem!



G I N

Fly safely, and...**ENJOY!**

GIN team



# HARNESSE DIAGRAM

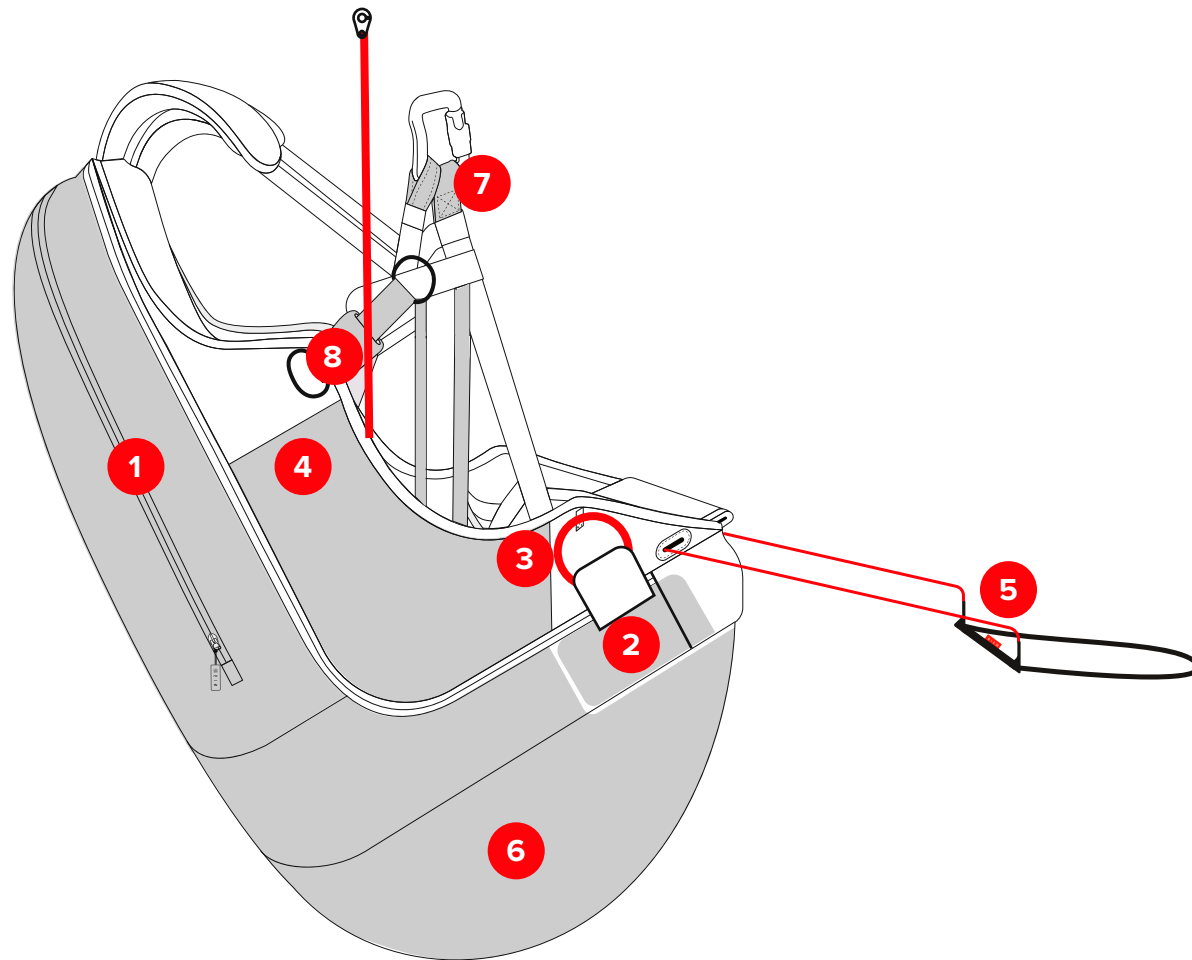

- 1 Back pocket
- 2 Rescue container
- 3 Rescue handle
- 4 Side pocket
- 5 Speed bar
- 6 Air Bag
- 7 Riser connection point
- 9 Back incline adjustment



**Gin Gliders INC.**

2318-32, Baegok-daero, Moyheon-myeon,  
Cheoin-gu, Yongin, Gyeonggi-do, Korea  
17063

tel. +82 (0)31 333 1241

fax. +82 (0)31 334 6788

gin@gingliders.com

**[www.gingliders.com](http://www.gingliders.com)**